

# 1 Tonne Powerswivel Hydrostatic

MACH202

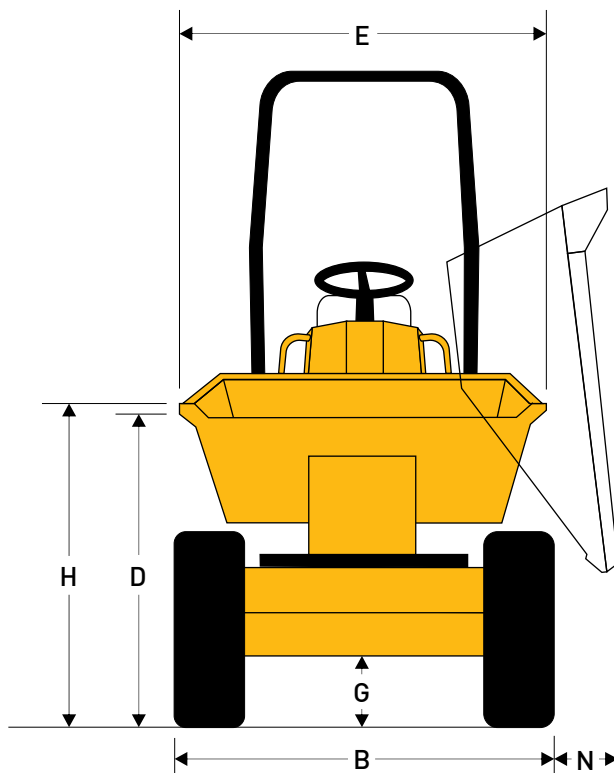
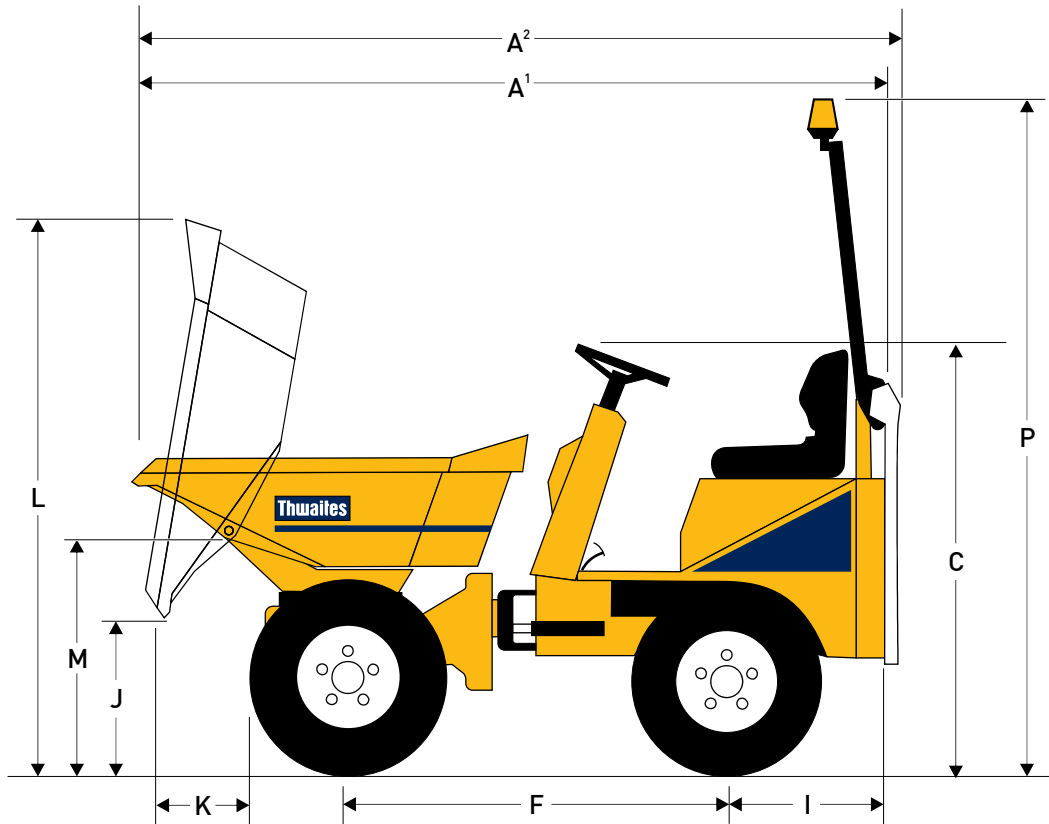

Dimensions (mm)

A <sup>1</sup>	3062
A <sup>2</sup>	3222
B	1195
C	1773
D	1204
E	1151
F	1500
G	274
H	1256
I	654
J	642
K	461
L	2244
M	901
N	154
P	2860

# 1 Tonne Powerswivel Hydrostatic

MACH202

Capacities		
	Max safe load	1000 kg
	Heaped	585 litres
	Struck	430 litres
	Water	355 litres

## Engine

Yanmar 3TNV76, 15.9 kW/21.4 bhp (nett) @ 2800 rpm, 3-cylinder water-cooled diesel. Max torque 66.4 Nm (49 lb f ft). Electric starting, hour meter, battery isolator switch and heavyduty cyclonic air cleaner positioned within the lockable engine compartment.

## Noise Levels

Operator's ear 84 LpA, airborne sound power level 101 LwA (to 2000/14/EC).

Speeds	Forward / reverse	0-12 km/h
--------	-------------------	-----------

Tyres	Standard
	10.0/75 x 15.3
	8 Ply
	Track grip tread

## Brakes and Axles

Automatic failsafe braking system incorporated into rear drive motors.

## Chassis

Front and rear chassis constructed from folded steel plate, with centre-point articulation and oscillation for optimum stability and traction.

## Drive System

Hydrostatic with variable displacement pump feeding four wheel motors, incorporating "Twin-Lock" system to maximise traction.

## Skip

Hydraulically operated, 4 mm steel base plate, fully welded, mouth and sides of skip reinforced with box sections giving greater strength to minimise skip damage. No material traps. Powerswivel mounted on ball-bearing turntable with powered rotation through 180° by means of twin slewing cylinders, operated by a single dual-axis control lever.

## Seating & Controls

Column-mounted forward/reverse lever with foot pedal speed control. Adjustable suspension seat, accessible from both sides. Audible warning device at key start 'on' position. Super-bright warning lights for all critical functions. Electric horn.

## Service Access

Lockable three-sided cover provides easy access from ground level to engine service points.

## Electrics

Wiring harness contained within conduits and all electrical components water resistant to IP65/67 standards.

## Steering & Hydraulics

Hydraulic power steering. Return line filtration for all services and large capacity suction strainer in the tank to give full circuit protection. Hydraulic test point fitted as standard.

Tank Capacities	Fuel	21 litres
	Hydraulic	20 litres

Shipping Cube	6.8 m <sup>3</sup> (with folded ROPS)
---------------	---------------------------------------

Unladen Weight	1300 kg
----------------	---------

Clearance Diameter	5.55 m
--------------------	--------

## ROPS/Beacon

A folding ROPS bar and beacon are fitted as standard.

## Optional EXtras

Full road lighting equipment. Reverse alarm. UK road equipment. Towing bracket. Sand tyres.

Distributor

# Thwaites

Thwaites Ltd. Leamington Spa, Warwickshire CV32 7NQ, England  
 Tel +44 (0)1926 422471 Fax +44 (0)1926 337155  
 www.thwaitesdumpers.co.uk



We reserve the right to change all specifications without prior notice.  
 Printed in England 08/2017